

1 CRANK CASE

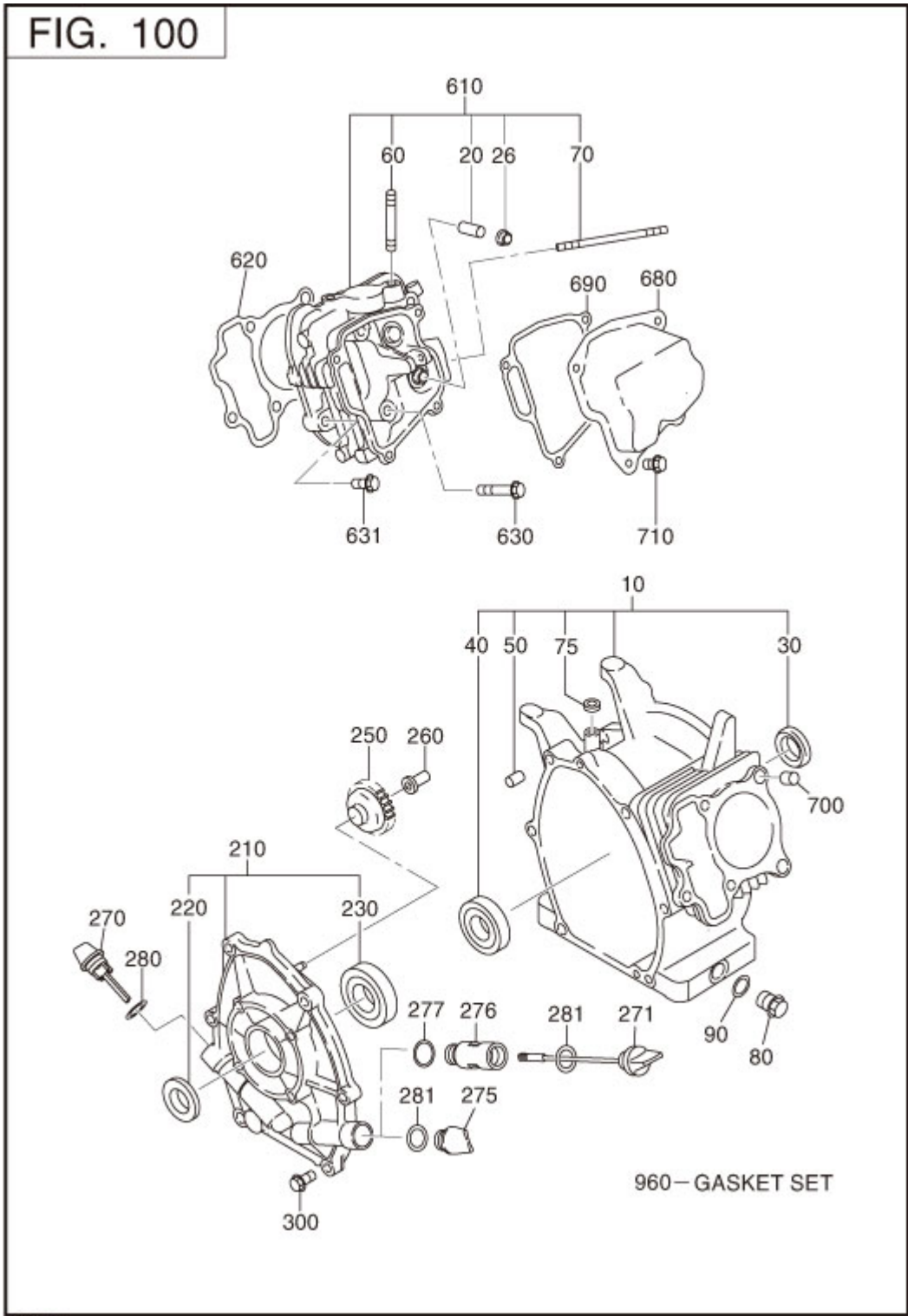

REF.	PART NUMBER	PART NAME	CODE NO.	QTY	REMARKS	INTERCHANGE
10	277-10102-31	CRANK CASE CP	5965-	1	W/OIL SENSOR	277-10102-41
	277-10102-21	CRANK CASE CP	5631-5964	1	W/OIL SENSOR	277-10102-31
	277-10102-11	CRANK CASE CP	5570-5630	1		277-10102-21
	277-10102-01	CRANK CASE CP	-5569	1	W/OIL SENSOR	277-10102-11
20	237-14202-03	VALVE GUIDE	-	2	5.5DX9.5DX27L	
26	277-16010-01	STEM SEAL	-	1	5.5DX9.5DX15DX7.8B	
30	044-02502-00	OIL SEAL	-	1	25DX38DX7B	
40	060-02800-20	BALL BEARING	-	1	28DX58DX16B	060-02800-21
50	277-15011-03	PIPE KNOCK	-	2	10.3DX8.5DX14L	
60	010-50802-50	STUD	-	2	M8X1.25X25L	
70	010-50603-51	STUD	-	2	M6X1.0X98L	
75	044-00600-20	OIL SEAL	-	1	6DX10DX2.5B	
80	040-11400-30	PLUG	-	2	M14X1.5X20DX12L	
90	021-11400-20	GASKET	-	2	14.1DX19DX2.3T	
210	277-11002-11	MAIN BEARING COVER C	5753-	1	FLANGE 4-5/16-24UNF	277-11002-21
	277-11002-01	MAIN BEARING COVER C	-5752	1	FLANGE 4-5/16-24UNF	277-11002-11
220	044-02502-10	OIL SEAL	-	1	25DX41.25DX6B	
230	060-02500-10	BALL BEARING	-	1	6205 25DX52DX15B	
250	277-45004-21	GOVERNOR GEAR CP	-	1	53DX28.8T N=33	
260	263-41901-03	GOVERNOR SLEEVE	-	1	6DX7.6DX16DX26L	
270	277-63601-03	OIL GAUGE	-	1	M18X1.5 L=70+18	277-63601-13
275	277-65001-03	FILLER PLUG	-	1	M18X1.5 L=12+18	
280	021-31600-20	GASKET	-	1	16DX23DX1.2T RUBBER	
281	021-31600-20	GASKET	-	1	16DX23DX1.2T RUBBER	
300	001-04083-50	FLANGE BOLT	-	6		
610	277-13001-01	CYLINDER HEAD CP	-	1		
620	277-15001-13	GASKET (HEAD)	-	1	T=0.2	
630	011-00802-40	FLANGE BOLT	-	4	M8X1.25X16DX68L	
631	001-04083-50	FLANGE BOLT	-	1		
680	277-15501-01	ROCKER COVER CP	-	1		
690	277-16001-03	GASKET(ROCKER COVER)	-	1	T=0.7	
700	277-15011-03	PIPE KNOCK	-	2	10.3DX8.5DX14L	
710	011-00600-20	FLANGE BOLT	-	4	M6X1.0X14DX12L	
960	277-99001-07	GASKET SET	-	1		

2 CRANKSHAFT,PISTON

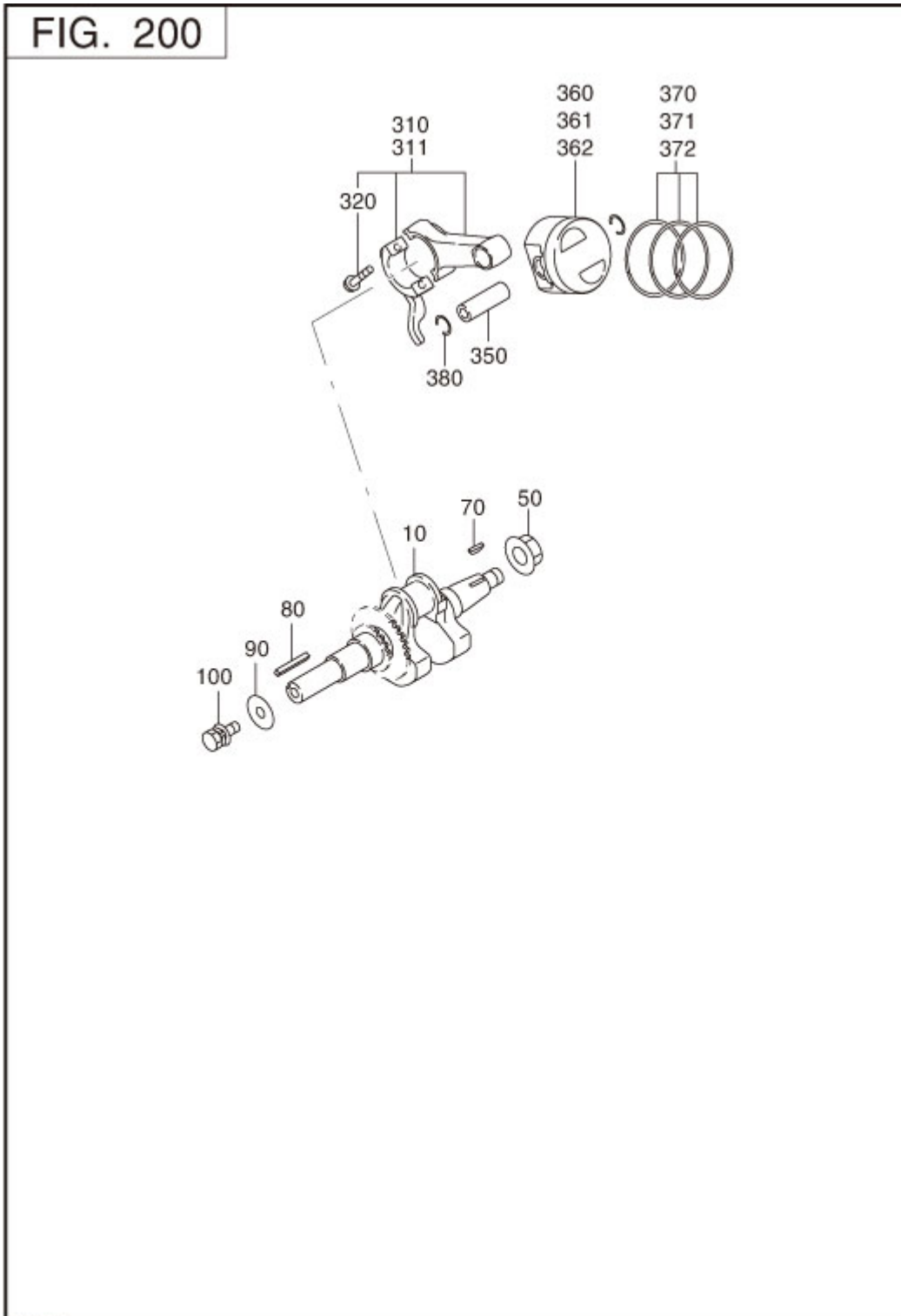

REF.	PART NUMBER	PART NAME	CODE NO.	QTY	REMARKS	INTERCHANGE
10	277-21201-01	CRANKSHAFT CP	-	1	L=271 17DX1/5TAPER	277-21201-11
50	018-01400-20	FLANGE NUT	-	1	M14X1.5X28DX12H	
70	032-30300-10	WOODRUFF KEY	-	1	3BX6HX16D	
310	277-22501-10	CONNECTING ROD AY	-	1	84.5CDX25B 30D-16D	
320	277-23001-03	CONNECTING ROD BOLT	-	2	M6X1.0X13DX33L	
350	277-23301-03	PISTON PIN	-	1	16DX11DX48.5L	
360	277-23401-03	PISTON	-	1	STD.(67DX40H)	
361	277-23403-03	PISTON	-	1	0.25 O.S.(67DX40H)	
362	277-23404-03	PISTON	-	1	0.50 O.S.(67DX40H)	
370	277-23501-07	PISTON RING SET	-	1	STD. OIL:3 PIECES	
371	277-23502-07	PISTON RING SET	-	1	0.25 O.S. OIL 3PIECE	
372	277-23503-07	PISTON RING SET	-	1	0.50 O.S. OIL 3PIECE	
380	056-51600-10	CLIP	-	2	17.1DX1.4D	

### 3 INTAKE EXHAUST

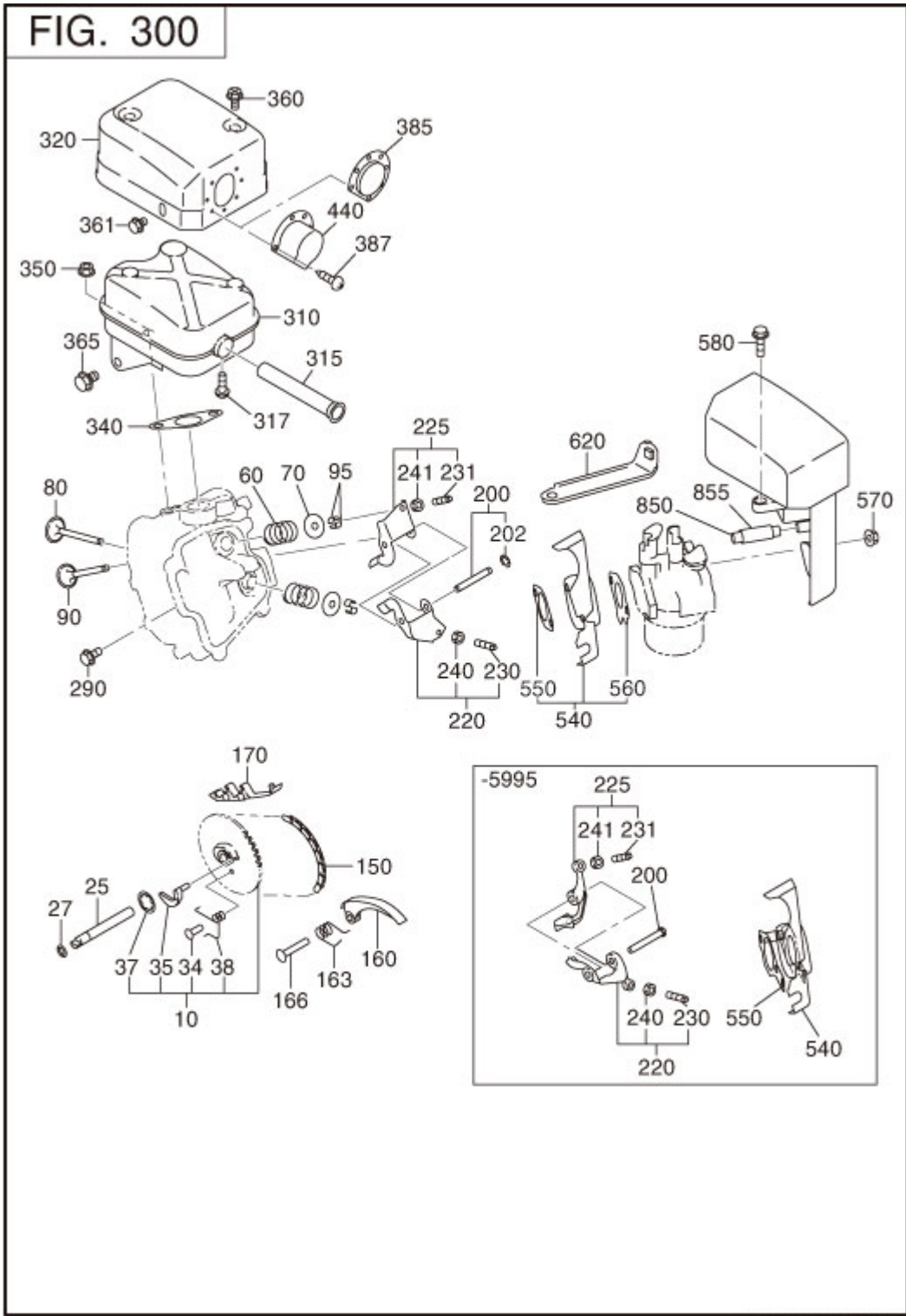

REF.	PART NUMBER	PART NAME	CODE NO.	QTY	REMARKS	INTERCHANGE
10	277-31601-01	CAM SHAFT CP	-	1	85DX2.9B N=40	
25	277-35101-03	PIN(CAM SHAFT)	-	1	9DX78.5L	
27	024-00600-10	O RING	-	1	5.8DX9.6D	
34	277-38601-03	PIN(SPRING)	-	1	4DX8DX9L	
35	277-36401-03	RELEASE LEVER	-	1		
37	277-36501-03	CLIP	-	1	13.8DX20.3DX0.4T	
38	277-38701-03	RETURN SPRING	-	1	5.3DX0.6DX6L N=6	
60	279-33601-03	VALVE SPRING	-	2	19.2DX2.3DX27L N=6	
70	269-33701-03	SPRING RETAINER	-	2	8.6DX26DX9.3T	
80	277-33401-13	INTAKE VALVE	-	1	25.5DX5.5DX68.1L	
90	277-33501-13	EXHAUST VALVE	-	1	23.5DX5.5DX68.1L	
95	132-10KA0-31	COLLET-VALVE	-	4		
150	277-35601-01	TIMING CHAIN CP	-	1	88 LINK	
160	277-36911-03	TENTIONER	-	1		
163	277-37101-03	SPRING(TENTIONER)	-	1	10DX1.8DX12L N=5	
166	277-36902-03	PIN(TENTIONER)	-	1	6DX13DX34L	
170	277-36913-13	CHAIN GUIDE	-	1		
200	277-35001-13	PIN(ROCKER)	5661-	1	6DX9DX41L	277-35001-23
	277-35001-03	PIN(ROCKER)	-5660	1	6DX9DX41L	277-35001-13
220	277-36101-00	ROCKER ARM(IN) AY	-	1		
225	277-36102-00	ROCKER ARM(EX) AY	-	1		
230	014-90500-10	ADJUST SCREW	-	1	M5X0.5X23L	
231	014-90500-10	ADJUST SCREW	-	1	M5X0.5X23L	
240	017-00500-20	NUT	-	1	M5X0.5X4.1H	
241	017-00500-20	NUT	-	1	M5X0.5X4.1H	
290	011-00600-20	FLANGE BOLT	-	1	M6X1.0X14DX12L	
310	277-30101-11	MUFFLER CP	-	1		
320	277-34201-01	MUFFLER COVER CP	-	1		277-34201-11
340	277-35201-03	GASKET(MUFFLER)	-	1	T=0.2 26D 9DX58P	
350	980-20082-80	FLANGE NUT	-	2		
360	015-20600-90	TAPPING BOLT	-	2	M6X13DX10L	
361	011-00600-10	FLANGE BOLT	-	1	M6X1.0X14DX8L	
365	011-00801-50	FLANGE BOLT	-	1	M8X1.25X16DX12L	
540	277-32901-13	INSULATOR	-	1		
550	277-35901-13	GASKET(INSULATOR)	-	1		

REF.	PART NUMBER	PART NAME	CODE NO.	QTY	REMARKS	INTERCHANGE
570	002-38060-00	FLANGE NUT	-	2		
580	011-00600-50	FLANGE BOLT	-	1	M6X1.0X13DX20L	
850	085-10800-00	RUBBER PIPE	-	1	8DX11D	

### 3 AIR CLEANER

**FIG. 315**

#### URETHANE FOAM

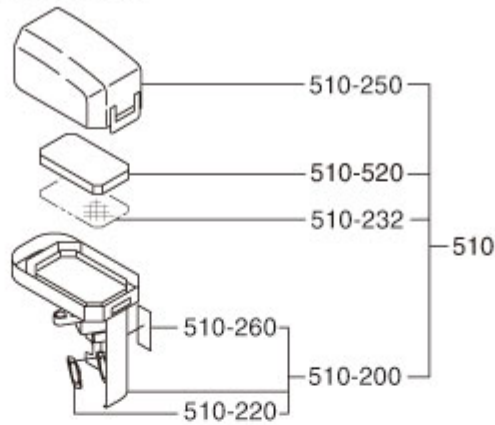

#### DUAL ELEMENT

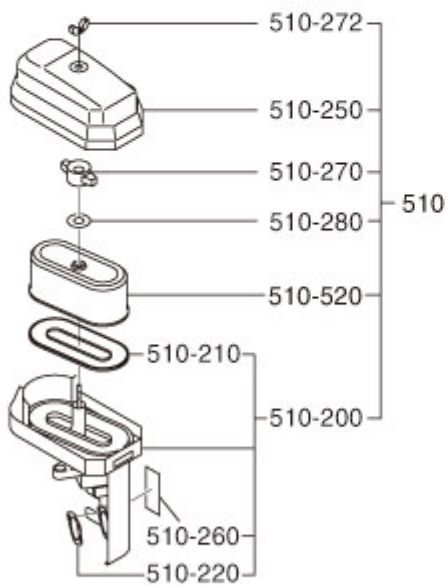

#### PRE CLEANER

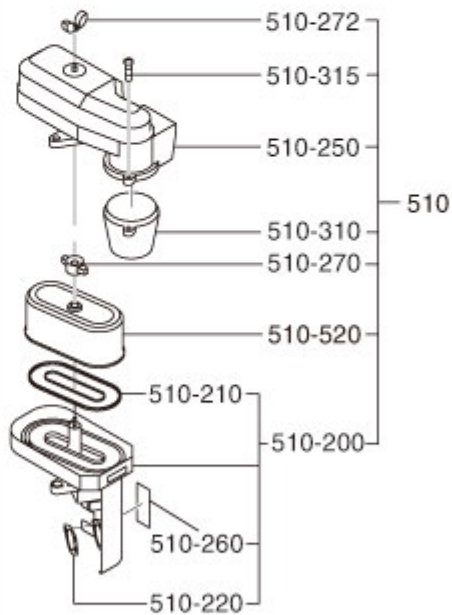



REF.	PART NUMBER	PART NAME	CODE NO.	QTY	REMARKS	INTERCHANGE
510	277-32612-00	AIR CLEANER AY	-	1	DUAL	
-200	277-32605-08	BASE CP	-	1		
-210	277-32610-08	PACKING	-	1		
-220	277-32604-08	PACKING	-	1		
-250	277-32602-08	COVER CP	-	1		
-260	277-32609-08	LABEL	-	1		
-270	277-32607-08	WING NUT	-	1		
-280	277-32608-08	WASHER	-	1		
520	277-32611-07	ELEMENT SET	-	1	DUAL	

### 4 GOVERNOR OPERATION

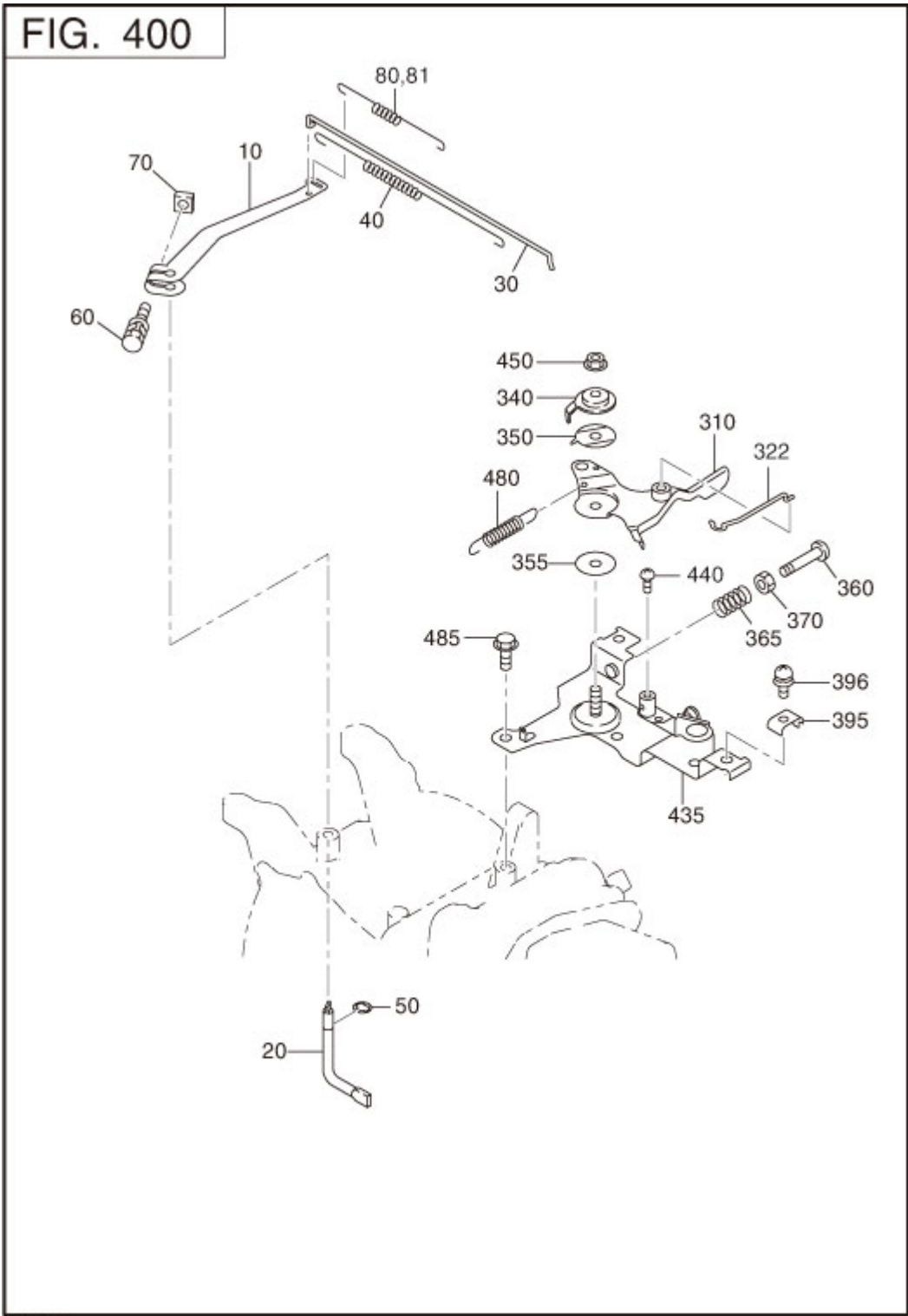

REF.	PART NUMBER	PART NAME	CODE NO.	QTY	REMARKS	INTERCHANGE
10	277-42301-13	GOVERNOR LEVER	-	1		
20	277-42201-33	GOVERNOR SHAFT	5600-	1		
	277-42201-23	GOVERNOR SHAFT	5539-5599	1		277-42201-33
	277-42201-13	GOVERNOR SHAFT	-5538	1		277-42201-23
30	277-42701-01	GOVERNOR ROD CP	-	1		
40	277-42801-13	ROD SPRING	-	1	7DX0.5DX182L N=16	
50	003-13050-00	CLIP	-	1		
60	013-00602-40	BOLT AND WASHER AY	-	1	M6X1.0X25L W/TWO W	
70	018-60600-20	NUT	-	1	M6X1.0X4.9H SQUARE	
80	276-42505-43	GOVERNOR SPRING	-	1		
310	277-43301-13	SPEED CONTROL LEVER	-	1		
340	277-43501-03	STOP PLATE	-	1		
350	020-00601-70	WASHER	-	1	6DX24DX0.4T	
355	021-70600-70	FRICTION WASHER	-	1	6.5DX24DX0.8T NYLON	
360	014-00601-80	SCREW	-	1	M6X1.0X35L	
365	237-45004-23	SPRING (ADJUST)	-	1	6.9DX0.9DX20L N=7	
370	002-17060-00	NUT	-	1		
435	277-46001-01	SPEED CONT.BRKT CP	-	1		
450	002-35060-00	SELF LOCK NUT	-	1		
485	011-00600-20	FLANGE BOLT	-	2	M6X1.0X14DX12L	

5 COOLING STARTING

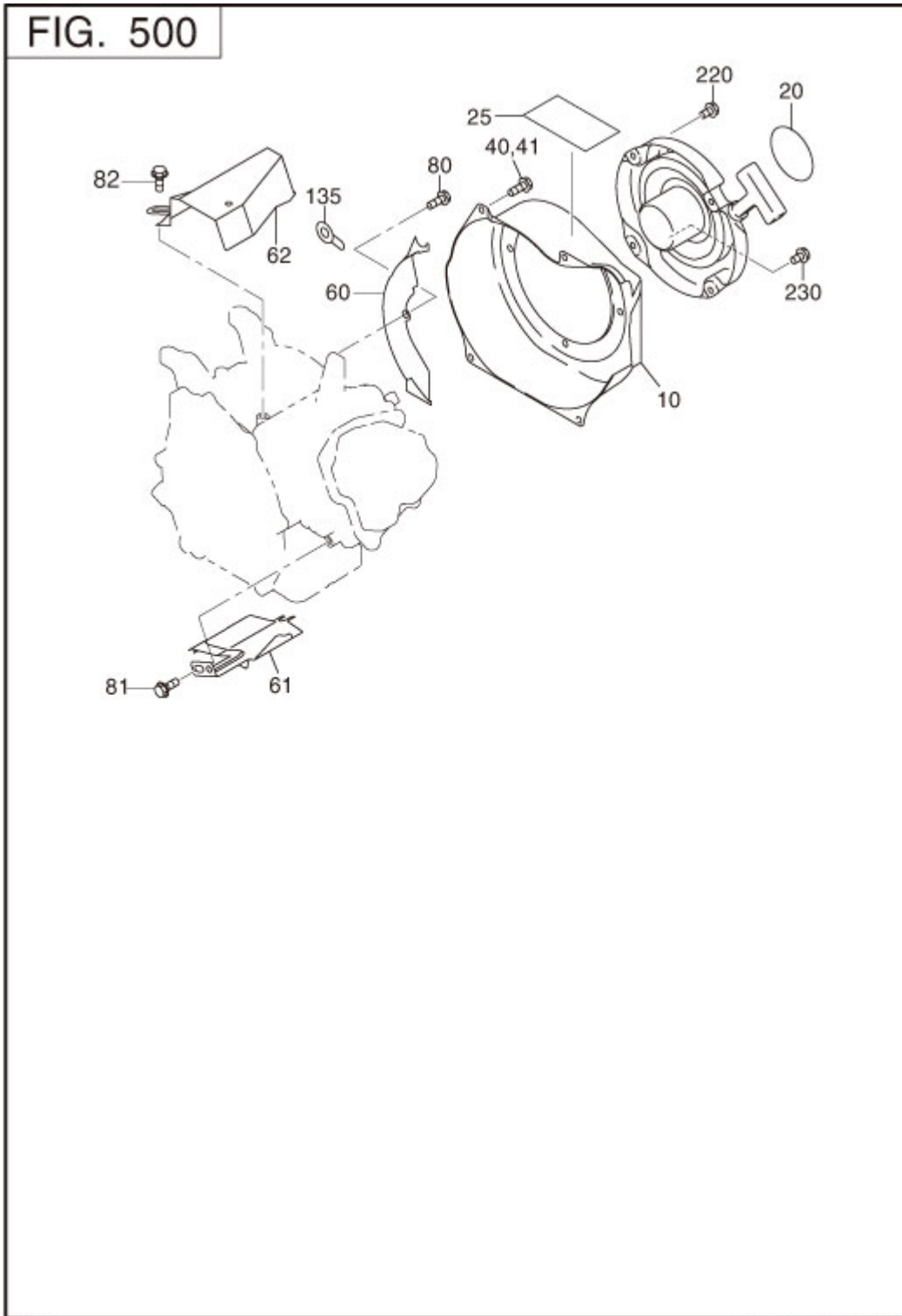

REF.	PART NUMBER	PART NAME	CODE NO.	QTY	REMARKS	INTERCHANGE
10	277-51201-01	BLOWER HOUSING CP	-	1	NEW R YELLOW	
20	073-20051-40	LABEL(TRADE MARK)	-	1	64D	
40	011-00600-30	FLANGE BOLT	-	4	M6X1.0X14DX14L	
60	277-52711-11	BAFFLE 1(CASE) CP	5631-	1		
	277-52711-01	BAFFLE 1(CASE) CP	-5630	1		
61	277-52702-03	BAFFLE 2(HEAD)	-	1		
80	001-04061-60	FLANGE BOLT	5631-	1		
	011-00600-20	FLANGE BOLT	-5630	1	M6X1.0X14DX12L	
81	011-00600-20	FLANGE BOLT	-	1	M6X1.0X14DX12L	
220	011-00600-10	FLANGE BOLT	-	4	M6X1.0X14DX8L	

### 5 RECOIL STARTER

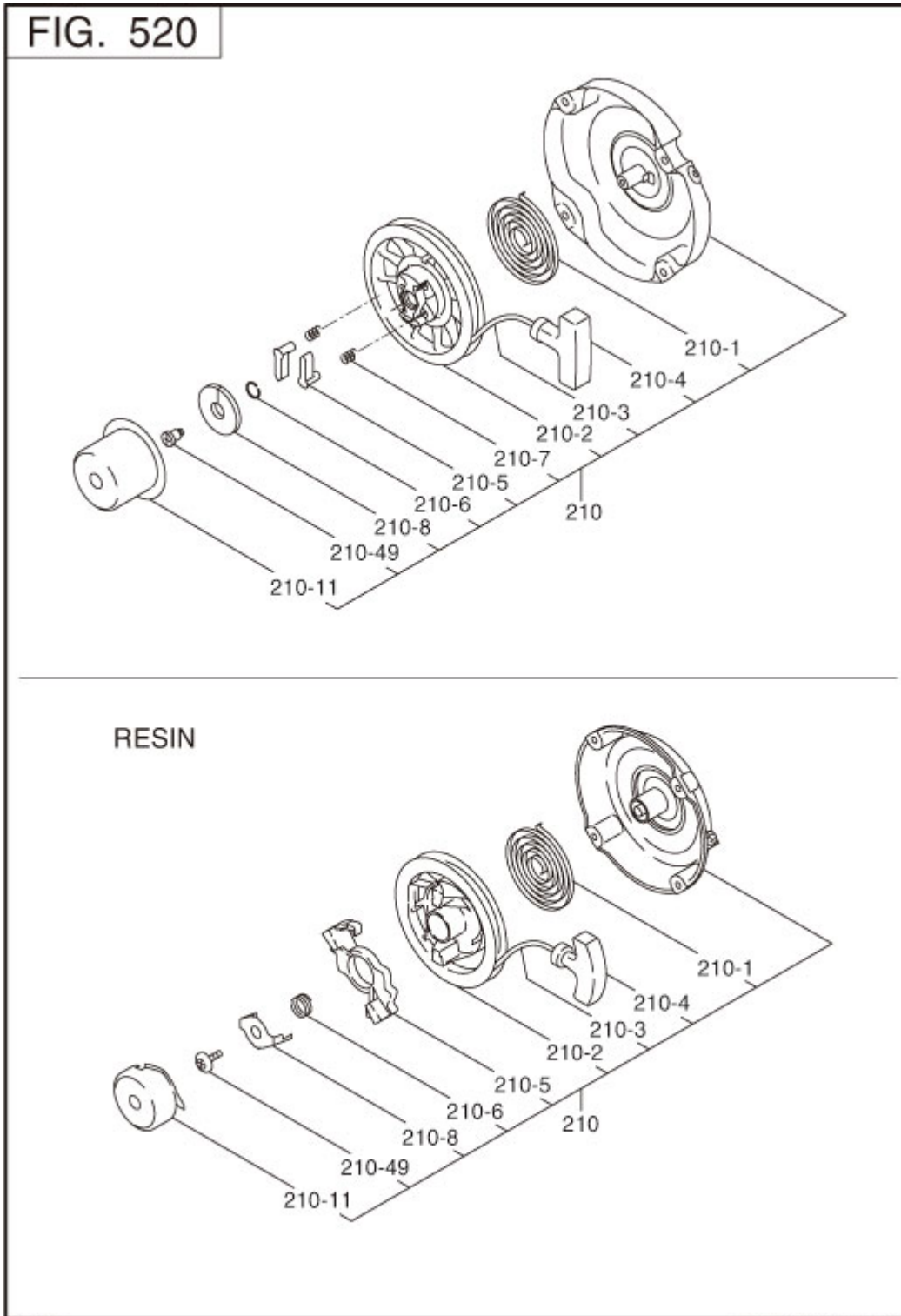

REF.	PART NUMBER	PART NAME	CODE NO.	QTY	REMARKS	INTERCHANGE
210	269-50201-20	RECOIL STARTER AY	-	1	D 160PD	
- 1	270-50115-08	SPIRAL SPRING	-	1		
- 2	269-50120-08	REEL	-	1		
- 3	269-50112-08	STARTER ROPE	-	1		
- 4	261-50100-08	STARTER KNOB	-	1		
- 5	270-50125-08	RATCHET	-	2		
- 6	227-50131-08	FRICTION SPRING	-	1		
- 11	269-50145-18	STARTER PULLEY	-	1		
- 35	270-50261-08	RATCHET GUIDE	-	1		
- 49	227-50152-08	SET SCREW	-	1		

6 FUEL LUBRICANT

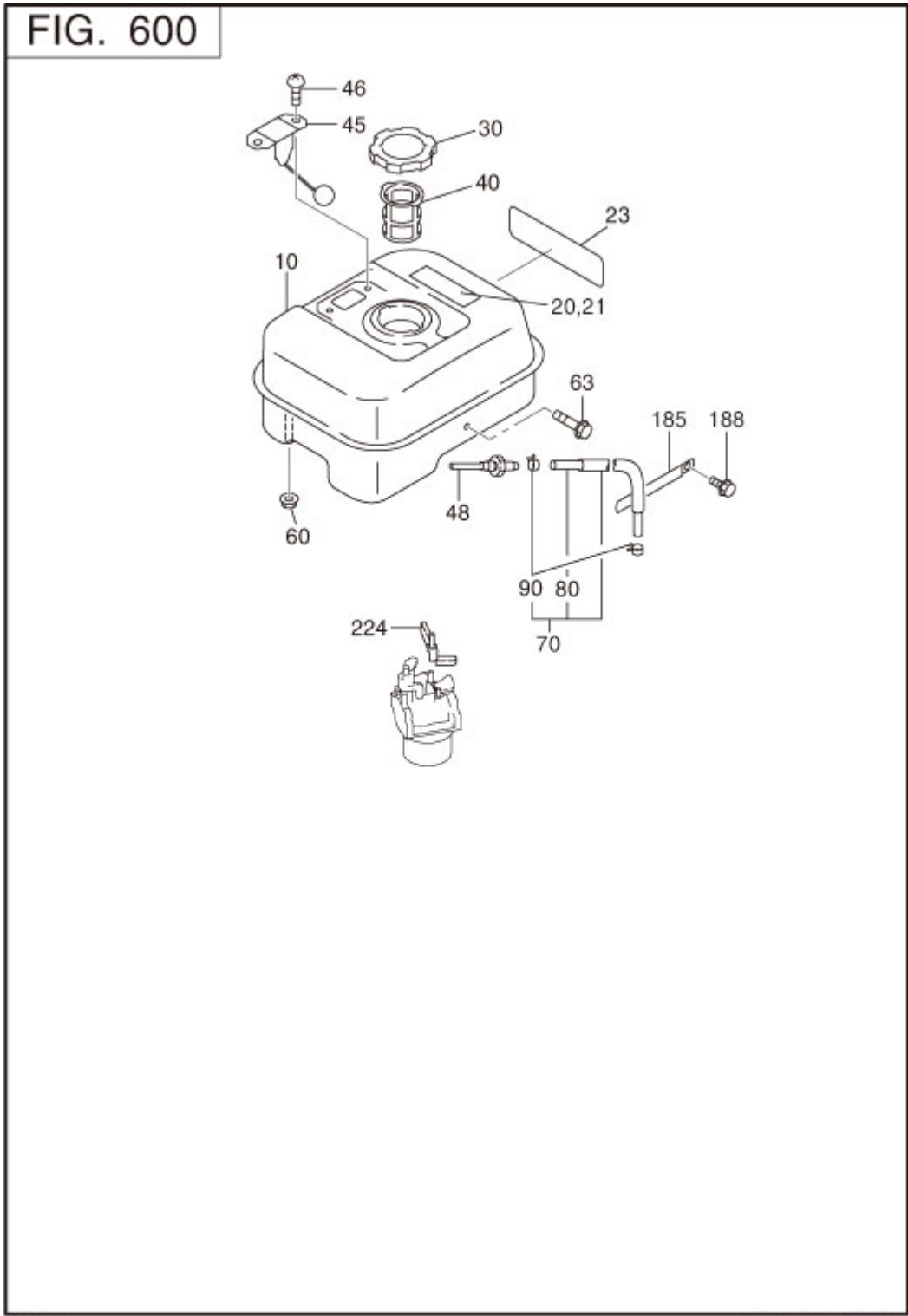



REF.	PART NUMBER	PART NAME	CODE NO.	QTY	REMARKS	INTERCHANGE
10	277-60101-01	FUEL TANK CP	-	1	3.6L NEW R YELLOW	
20	073-20051-80	LABEL(WARNING)	-	1	42X104 ENGLISH	
23	277-95101-03	LABEL(MODEL)	-	1	28X99	
30	043-04400-50	FUEL TANK CAP CP	-	1	43DX68DX14H BLACK	
40	064-13600-10	FUEL FILTER	-	1	36DX46DX43H	
48	050-51200-20	UNION	-	1	M12X4DX78L W/FILTER	
60	002-38060-00	FLANGE NUT	-	2		
63	011-00601-30	FLANGE BOLT	-	1	M6X1.0X14DX25L	
80	085-10600-00	RUBBER PIPE	-	1	6DX12D	
90	056-11000-30	HOSE CLAMP	-	2	10DX8BX1T	
224	277-43801-01	CHOKE LEVER CP	-	1		

### 6 CARBURETOR

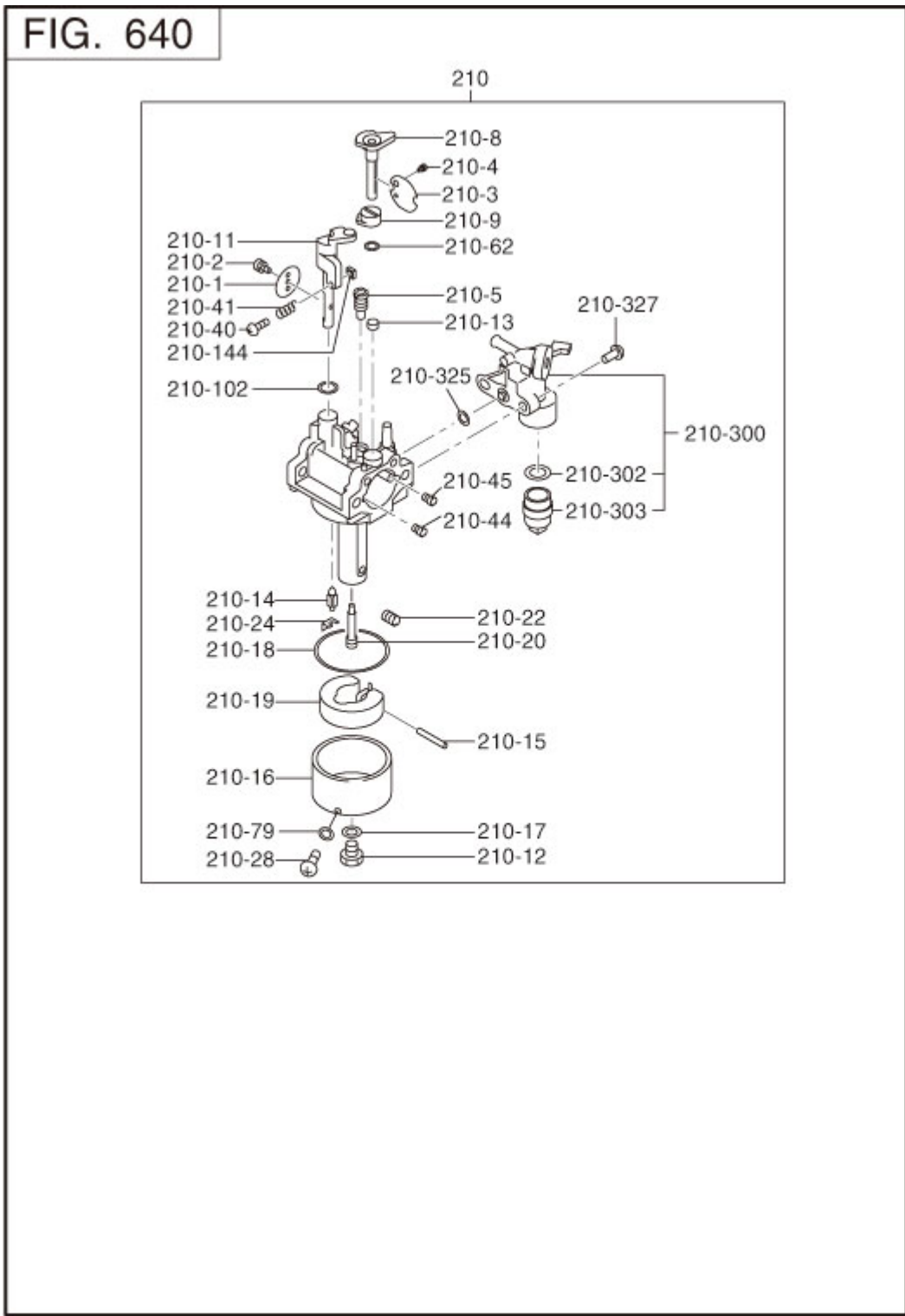

REF.	PART NUMBER	PART NAME	CODE NO.	QTY	REMARKS	INTERCHANGE
210	277-62302-10	CARBURETOR AY	5631-	1		
	277-62302-00	CARBURETOR AY	-5630	1		277-62302-10
- 1	277-62535-08	THROTTLE VALVE	5631-	1	#160	
	277-62535-08	THROTTLE VALVE	-5630	1	#160	
- 2	209-62351-08	SCREW	5631-	1		
- 3	277-62525-08	CHOKE VALVE	5631-	1		
	277-62525-08	CHOKE VALVE	-5630	1		
- 5	246-62420-08	PILOT JET	5631-	1	#40	
	246-62420-08	PILOT JET	-5630	1	#40	
- 8	277-62520-08	CHOKE LEVER	5631-	1		
	277-62520-08	CHOKE LEVER	-5630	1		
- 11	277-62531-08	THROTTLE SHAFT	5631-	1		
	277-62531-08	THROTTLE SHAFT	-5630	1		
- 12	227-62451-08	BOLT	5631-	1		
	227-62451-08	BOLT	-5630	1		
- 14	277-62500-08	NEEDLE	5631-	1		
	277-62500-08	NEEDLE	-5630	1		
- 15	277-62515-08	PIN	5631-	1		
	277-62515-08	PIN	-5630	1		
- 16	277-62506-08	FLOAT BODY	5631-	1		
	277-62506-08	FLOAT BODY	-5630	1		
- 17	214-62450-08	PACKING	5631-	1		
	214-62450-08	PACKING	-5630	1		
- 18	214-62540-08	CHAMBER PACKING	5631-	1		
	214-62540-08	CHAMBER PACKING	-5630	1		
- 19	226-62506-08	FLOAT AY	5631-	1		
	226-62506-08	FLOAT AY	-5630	1		
- 20	277-62440-08	MAIN NOZZLE	5631-	1		
	277-62440-08	MAIN NOZZLE	-5630	1		
- 22	226-62412-08	MAIN JET	5631-	1		
	277-62401-08	MAIN JET	-5630	1	#76.3	
- 24	226-62701-18	CLIP	5631-	1		
	226-62701-08	CLIP	-5630	1		
- 28	277-62360-08	BOLT	5631-	1		
	277-62350-08	BOLT	-5630	1		

REF.	PART NUMBER	PART NAME	CODE NO.	QTY	REMARKS	INTERCHANGE
- 32	246-62390-08	SEAL	5631-	1		
	246-62390-08	SEAL	-5630	1		
- 44	248-62410-08	AIR JET	5631-	1		
	105-62410-08	AIR JET	-5630	1		
- 45	106-62410-08	AIR JET(PILOT)	5631-	1		
	106-62410-08	AIR JET(PILOT)	-5630	1		
- 62	236-62680-08	SEAL	5631-	1		
	236-62680-08	SEAL	-5630	1		
-104	236-62541-08	PACKING	5631-	1		
	236-62541-08	PACKING	-5630	1		
-302	064-20064-10	PACKING	5631-	1		
	064-20064-10	PACKING	-5630	1		
-303	064-20078-10	CUP	5631-	1		
	064-20078-10	CUP	-5630	1		

7 ELECTRIC DEVICE

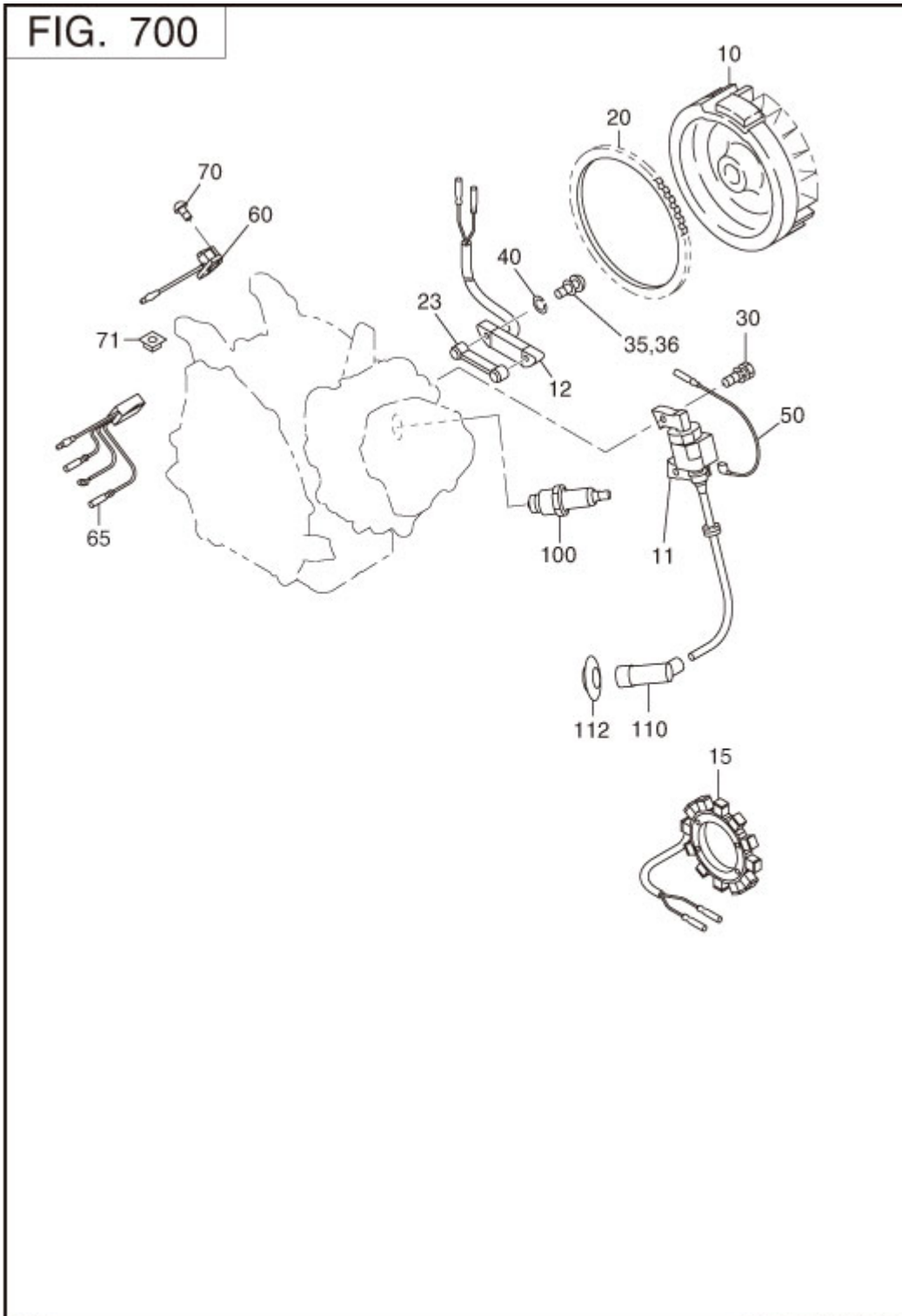

REF.	PART NUMBER	PART NAME	CODE NO.	QTY	REMARKS	INTERCHANGE
10	277-79230-01	FLYWHEEL CP	-	1		
11	277-79430-11	IGNITION COIL CP	-	1		
30	001-14062-50	BOLT AND WASHER AY	-	2		
50	277-73102-01	WIRE 2 CP	-	1	L=360 BLACK	
60	X66-00003-61	SWITCH AY	-	1		
70	015-00400-90	TAPPING SCREW	-	2	M4X10L	
100	065-01401-50	SPARK PLUG BR6HS	-	1	NGK BR6HS	
110	065-50002-70	SPARK PLUG CAP	-	1		

8 OIL SENSOR

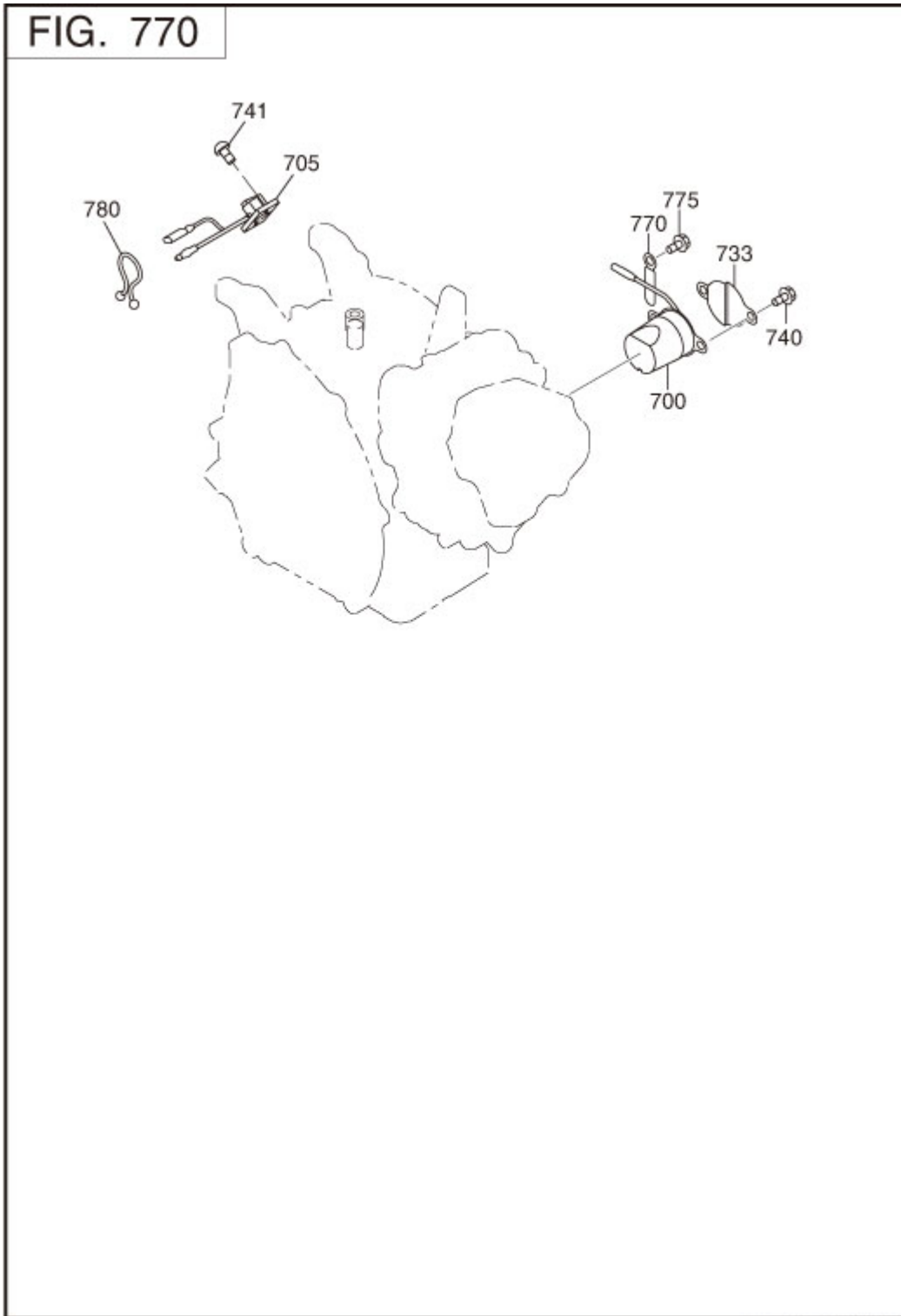

REF.	PART NUMBER	PART NAME	CODE NO.	QTY	REMARKS	INTERCHANGE
700	277-76301-01	OIL SENSOR CP	-	1		
705	KU3-11043-01	FLOAT C/U CP3	-	1		
740	001-14061-60	BOLT AND WASHER AY	-	2		
741	015-20500-10	TAPPING SCREW	-	1	M5X10L	
770	214-79006-01	CLAMP CP	-	1		
775	011-00600-20	FLANGE BOLT	-	1	M6X1.0X14DX12L	



9 ACCESSORIES LABEL

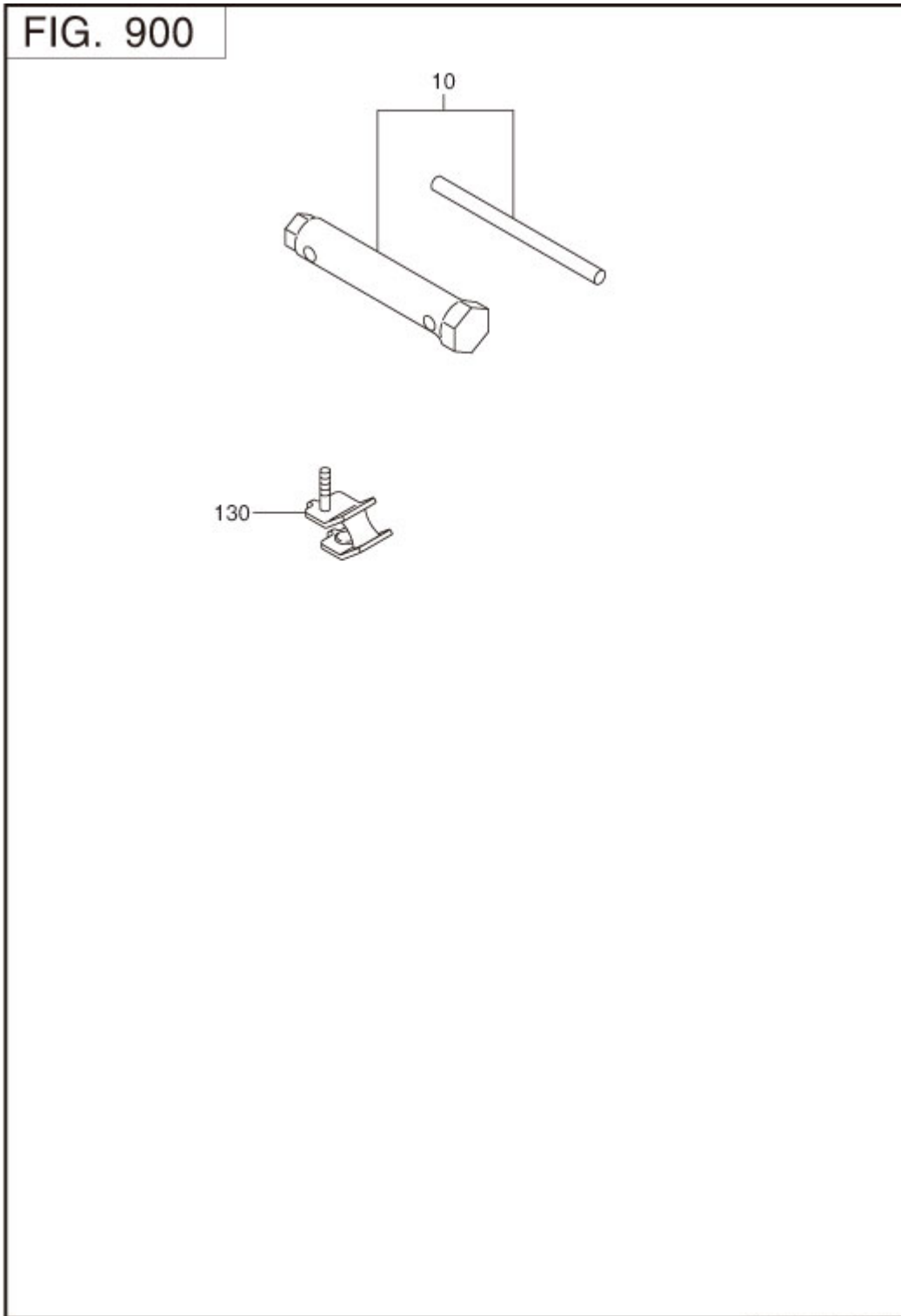

REF.	PART NUMBER	PART NAME	CODE NO.	QTY	REMARKS	INTERCHANGE
10	277-90301-H0	ACCESSORY TOOL KIT	-	1		